



CARDBOARD SKILLET SEALING SOLUTIONS

CARDBOARD SKILLET SEALING SOLUTIONS

As a result of a move towards cardboard packaging within the sandwich & ready-meal industry, TREPKO have developed their range of sealing equipment and can now provide manufacturers with a range of effective and proven machinery solutions to dispense & seal cardboard packaging.

TREPKO are able to offer three machinery solutions to suit various production requirements. These machines can cater for production requirements of between 20 and 100 pack per min..

An alternative to fully automatic machines, TREPKO can offer a semi-automatic 22 S sealing machine tailor made to suit smaller production requirements. This machine requires an operative to load and remove the sandwich skillets before & after the sealing process. Quick-release assemblies are utilised to allow for swift changeover times.

The newly developed 412 S twin lane machine is fully automatic and will dispense, erect and finally seal the cardboard skillets at an output speed of 60 packs per minute. Size change is simple with quick-release assemblies allowing for swift changeover times for the various width skillets available. This machine is also offered in a 'dual index' format which has an increased output speed of 100 packs per minute inline with fully automatic sandwich product equipment.



Machine 22 S

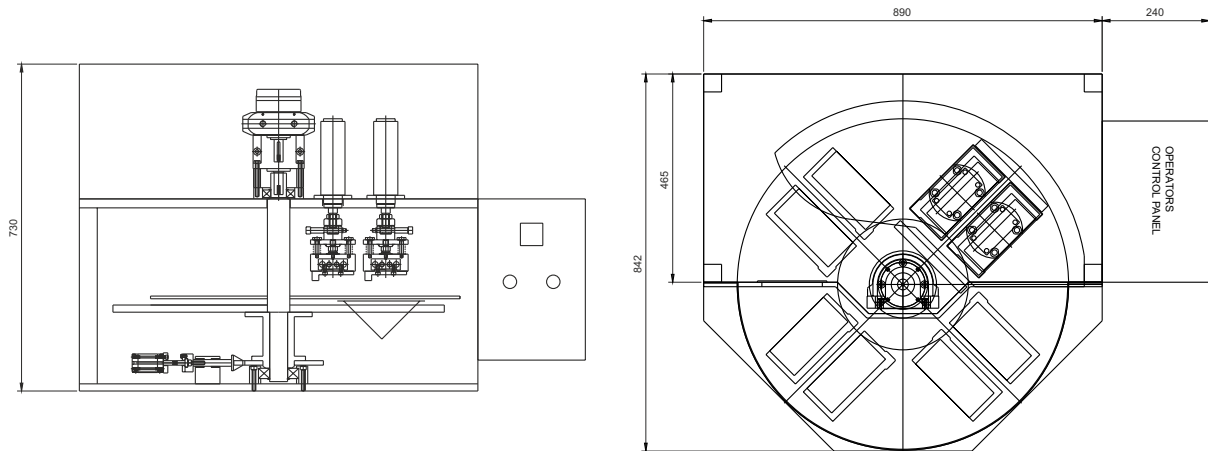

Automatic machine 412 / 422 S

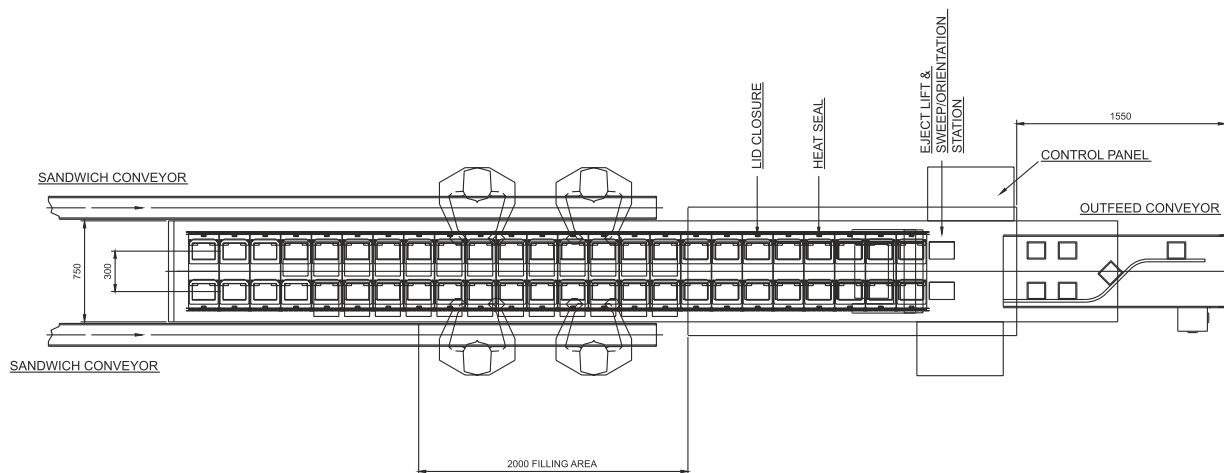

SPECIFICATIONS	22S	412S single index	422S dual index
Machine Output:			
- skillets per min	16-20 (*)	60	120
- skillets per hour	960-1200 (*)	3600	7200
Maximum skillet size (mm)	95	60-105	60-105
Services:			
- electrical supply	240V AC + N, 13 A	3x380-415V AC + N, 16A	3x380-415V AC+N, 16A
- compressed air (l/min)	65	300	400
Machine Weight (kg)	150	1500	1700
Machine Size (L x W x H) (mm)	1130 x 850 x 730	6260 x 1500 x 2080	6260 x 1500 x 2080

(*) subject to operator speed



Worldwide supplier 
of filling/packaging machines



info@trepko.com
www.trepko.com